

FIGHTER FK1425

MY19 • 4x2 • MANUAL OR ALLISON AUTO



GVM:
14,000kg



Power / Torque:
184kW / 761Nm



Wheelbase:
4,270mm (H) / 5,210mm (L)

- 30,000km service intervals
- Isringhausen driver's seat
- **NEW** 5yr / 300,000km Warranty (T&Cs inside)
- High-torque engine
- Low-height chassis

SPECIFICATIONS - FIGHTER FK1425

MODEL

4x2 FK1425	6 SP.	MAN	STEEL SUSP.	FK62FHZ1RFAC
4x2 FK1425	6 SP.	MAN	STEEL SUSP.	FK62FLZ1RFAC
4x2 FK1425	5 SP.	AUTO	STEEL SUSP.	FK62FLZ1RFAL
4x2 FK1425	5 SP.	AUTO	AIR SUSP.	FK65FLZ1RFAL

WHEELBASE (mm)

4,270 (H)
5,210 (L)
5,210 (L)
5,210 (L)

GVM (kg)

14,000
14,000
14,000
14,000

GCM (kg)

20,000
20,000
20,000
20,000

ENGINE

Engine Version	FUSO 6M60-9AT1 Diesel
Configuration	6 Cyl. In-line OHC, 4-Valve
Type	Variable Geometry Turbo Charged Air to Air Intercooler
Displacement	7.5 litre (7,545cc)
Power ECE Nett	177kW @ 2500rpm
Torque ECE Nett	745Nm @ 1400rpm
Power (JIS Gross)*	184kW (250ps)@ 2500rpm
Torque (JIS Gross)*	761Nm (561lb/ft) @ 1400rpm
Maximum Engine Speed (rpm)	2900
Compression Ratio	16.0:1
Cooling System/Oil Cooler	Water Cooled with Viscous Fan, 23L. Engine Oil Cooler
Air Cleaner	Paper Element Type with Restrictor Indicator. Vertical Intake Mounted on Clean Air Side (RH)
Cold Start Preheat	Standard
Emission Control	Selective Catalytic Reduction (SCR) After-Treatment System (BlueTec), Positive Crankcase Ventilation (PCV)
Emission Level	EURO 5 (ADR 80/03)

*Calculated

6M60-9AT1

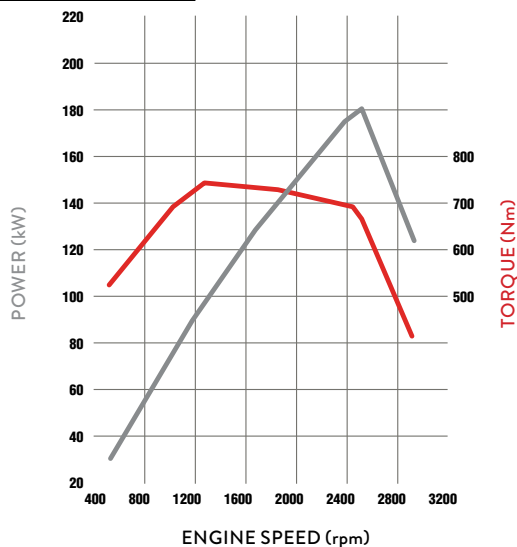

FUEL

Injection System	DENSO Common Rail System Electronically Controlled Direct Injection
Tank Type	Rectangular Steel Tank with Locking Cap
Fuel Capacity (L)	200
AdBlue Exhaust Fluid Capacity (L)	25

ELECTRICAL

Voltage	24V Negative Earth
Alternator Capacity	24V-80 amp
Battery Specification	Heavy Duty 2 x 12V, 100Ah/20hr
Headlamp Type	Halogen 2 x 70W/75W

CLUTCH

	Manual
Clutch Model	FUSO C7M38
Type	Single Plate Cerametallic 380mm
Operation/Specification	Air Assisted Hydraulic

TRANSMISSION

	Manual	Auto
Version	FUSO Manual M070S6-OD	Allison Automatic 2500 Series
Type/Speeds	6 with Air Assisted Gearshift	5 Speed with Power / Economy Mode
Features	Synchromesh 2nd-6th	Generation 5 Control Systems
Ratios	1st: 6.807 2nd: 4.172 3rd: 2.396 4th: 1.504 5th: 1.000 6th: 0.774 Rev. 6.807	1st: 3.512 2nd: 1.896 3rd: 1.439 4th: 1.000 5th 0.737 Rev. 5.086
PTO Opening	LH Side	LH and RH Side
Torque Converter/Stall Torque Ratio	N/A	TC222/1.58
Automatic Transmission Fluid Cooling	N/A	Cooler mounted in front of radiator

PROPELLER SHAFT

	Manual	Auto
Type	P10	P8
Universal Joint	Needle Roller	

FRONT AXLE

Axle	FUSO F500T "I" Beam
Design Capacity (kg)	5,000
Max Operating Capacity (kg)	5,000

FRONT SUSPENSION

Type	Taper Leaf Spring + Double Acting Shock Absorbers. Stabilizer Bar standard (FK62 models)
Size (mm)	1,300 x 70

REAR AXLE

Axle	FUSO D052 Full Floating Hypoid
Design Capacity (kg)	9,500
Max Operating Capacity (kg)	9,200
Ratio	Manual 4.875:1 Auto 5.428:1

REAR SUSPENSION

Type	Steel Suspension	Air Suspension
Details	Multi Leaf Spring + Stabiliser Bar	Trailing Arm + Air Dump Control and Double Acting Shock Absorbers
Size Main Leaves (mm)	1,300 x 70	Air Spring (2 x 270 dia. per axle)
Size Helper Leaves (mm)	900 x 70	Trailing Arm - 2 leaf

SPECIFICATIONS - FIGHTER FK1425

STEERING

Power Assisted	Tilt/Telescopic Adjustable Steering Wheel
----------------	---

BRAKES

Type	Full Air, Dual Circuit, FUSO Taper Roller, Automatic Brake adjustment, ABS
ASR (Traction Control)	Yes (Not available on auto model)
Size Front / Rear (mm)	370 x 150
Park Brake	Rear Wheel Spring Actuated
Auxiliary	Exhaust Brake
Compressor	Water Cooled, 340cc Single Cylinder with Air Dryer

WHEELS AND TYRES

Wheel Type	7, Single Piece Disc
Wheel Size	19.5 x 6.75DC-147-13t
Wheel Stud Pattern	8 Stud 275mm PCD ISO
Tyre Size All	265/70R19.5
Spare Tyre Carrier	Provided

CHASSIS

Type	Parallel Channel
Size (mm)	230 x 80 x 8.0
Width (mm)	844

Refer to the bodybuilders guidelines on the Fuso website (www.fuso.co.nz) before mounting a body or modifying the chassis

INSTRUMENTS

Gauges	Speedometer with Odometer, Tachometer; Air Pressure (2), Fuel Level; Water Temperature
Colour Information Display	Fuel Consumption; Service Indicators Hour Meter and Tripmeter

STANDARD FEATURES

Airbag	Driver's Air Bag and Seat Belt Pre-tensioners
Hill Start System	Yes (Not available on auto model)
Cab Cooling and Heating	Air Conditioner/Heater/Demister
Accessory Power	24V Accessory Power Outlet/Cigar Lighter
6.2" Touchscreen Media Unit	AM/FM/DAB + USB + AUX, Apple Carplay / Android Auto, Wi-Fi Enabled for Internet Radio, Bluetooth, 32GB Storage Capacity, HD Infrared Reverse Camera (see options) NEW
Driving	Keyless Central Locking, Electric Windows Cruise Control, LH Transom Window Cup Holders (4), Rear Quarter Glass Fluorescent Cabin Lamp and Interior Reading Lamps, Engine Idle Speed Control
Storage	Centre Seat Storage Console; Rear Bunk Storage Pocket, Dash Storage Tray 2 DIN Glove Compartment, 1 Single and 1 Double DIN Slot for Accessories Overhead Storage Pocket with Lid RH Door Storage Pocket
Cab: External	Roof Mounting Points (max. static load 70kg) Front End-Outline Marker Lamps

STANDARD FEATURES (continued)

Chassis	Mounted Tool Box, Reverse Warning Buzzer
---------	--

CAB FEATURES

Type	All Steel Forward Control, Manual Tilt 44 deg.
Mounting	Hydroelastic Susp. 4 Point
Colour	Natural White (W31)
Interior	Fully Trimmed
Windscreen	Laminated Tinted
Windscreen Wipers	2 Speed + Intermittent Cycle with Integrated Washer Nozzles
Door	90 degree Opening Angle
Rear Vision Mirrors	Remote/Heated with Convex Spotter (Both Sides)
Seating Capacity	3
Seat Belts	2 ELR Lap Sash, 1 Lap
Seat (driver)	ISRI Air Susp. + Auto Levelling, Height, Tilt, Lumbar, Bolster and Dampening Adjust, Integral Headrest, Fabric Trim NEW
Seats (passenger)	Centre: Low Back with Fabric Trim and forward folding, H Passenger: Fixed Base with Reclining Seat Back, Integral Headrest and Fabric Trim

SERVICE INTERVALS

30,000km full service / 15,000km safety inspection
30,000km full service intervals, depending on application/use.
15,000km safety inspection, with greasing, required for reliability and to maintain warranty cover.

WARRANTY

5 years / 300,000km **NEW**
Simply have your vehicle serviced at an authorised FUSO Service Centre, at the recommended servicing intervals, and you are covered by an additional 2 year / 150,000km FUSO warranty on top of the first 3 years / 150,000km. That's a total of 5 years / 300,000km cover.
Refer to terms and conditions in the FUSO warranty booklet for full details.

OPTIONS

Additional Cameras for Media Unit (up to 4) **NEW**
Truck Specific GPS Navigation
Reverse Sensors
Tyre Pressure Monitoring System (up to 36 tyres)
Wireless Phone Charging Pocket

PERFORMANCE

	Manual	Auto
Turning Circle (kerb to kerb - metres)	H = 15.2 L = 18.2	18.2
Electronically Speed Limited to (km/h):	100	100
Engine Speed (rpm) at 90km/hr (top gear)	2130	2260
Gradeability at Rated GVM (theoretical)*	39%	32%
Gradeability at Rated GCM (theoretical)*	26%	22%

*Theoretical performance only. Actual performance may vary under different conditions

KERB WEIGHTS AND MAX AXLE LOADS (kg)

Model	Vehicle Ratings**	Max Axle Loadings**		Kerb Weights*			
		GVM	GCM	Front	Rear	Total	
4x2 FK1425 6 Sp. Man Steel Susp. FK62FHZ1RFAC	14,000	20,000	5,000	9,200	2,320	1,550	3,870
4x2 FK1425 6 Sp. Man Steel Susp. FK62FLZ1RFAC	14,000	20,000	5,000	9,200	2,440	1,545	3,985
4x2 FK1425 5 Sp. Auto Steel Susp. FK62FLZ1RFAL	14,000	20,000	5,000	9,200	2,465	1,535	4,000
4x2 FK1425 5 Sp. Auto Air Susp. FK65FLZ1RFAL	14,000	20,000	5,000	9,200	2,460	1,590	4,050

* Weights (est.) includes 10L fuel and spare wheel and are subject to 2.5% variation (+/-)

** Vehicle ratings and max axle loadings may be limited by local regulations.

SPECIFICATIONS - FIGHTER FK1425

DIMENSIONS (mm)

	H Wheelbase	L Wheelbase		H Wheelbase	L Wheelbase
Wheelbase	4,270	5,210	Width Front Track	1,780	1,780
Length Overall	7,220	8,645	Width Rear Track	1,710	1,710
Height Overall	2,530	2,530	Width Frame	844	844
Width Overall	2,270	2,270	Height Frame at Rear Axle	932	931 (Air Sus = 858 inflated)
Width Rear Axle	2,270	2,270			

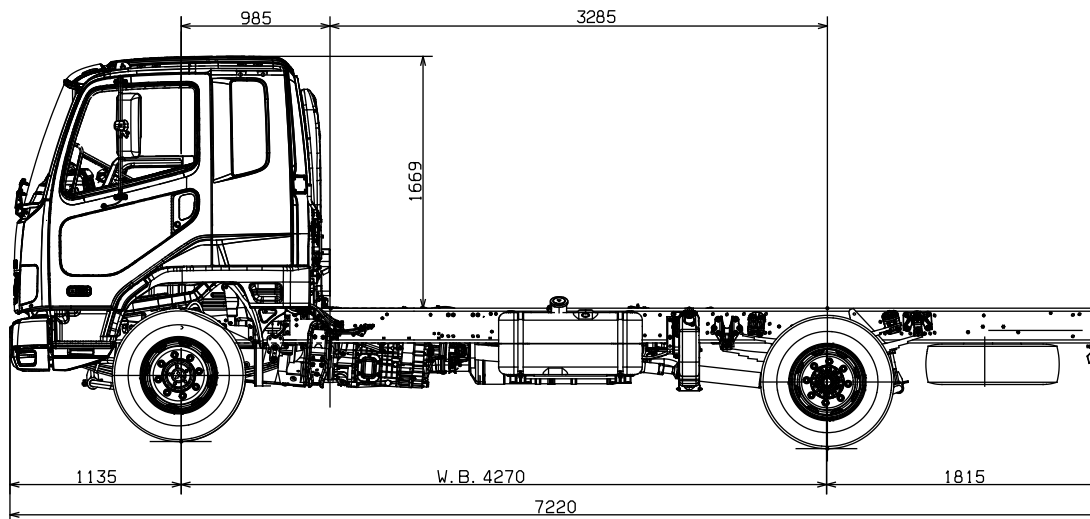

FIGHTER FK1425 – ‘H’ WHEELBASE

1000
UNIT: mm 20mm=1m

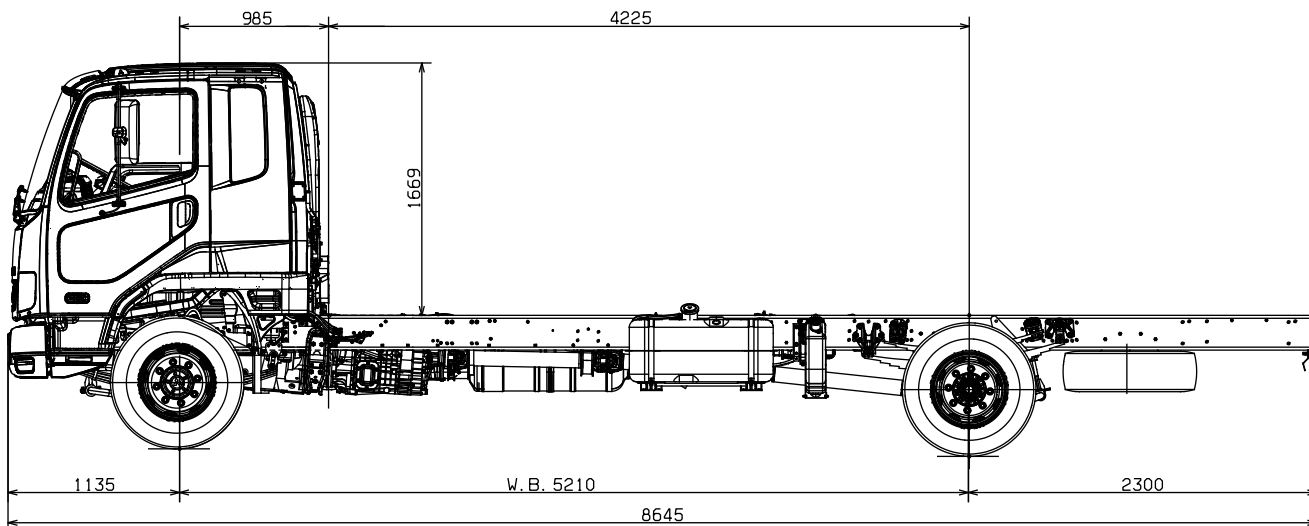

FIGHTER FK1425 – ‘L’ WHEELBASE

1000
UNIT: mm 20mm=1m

Scale = 1:50 (20mm = 1 metre). This scale is accurate when used on the original spec sheet, be aware that enlarging these illustrations can alter the scale and cause incorrect measurements. Fuso New Zealand and its authorised dealers always recommend customers seek professional advice from independent sources before commencing any engineering activities.

A policy of continual improvement means that specifications detailed in this brochure are subject to change without notice. Contact your authorised Fuso dealer to confirm current specifications. Fuso is a registered trademark of Mitsubishi Fuso Truck & Bus Corporation. Copyright © Fuso NZ (2017)