

MIGHTY EX9

Cab Chassis



MIGHTY EX9

Cab Chassis

Engine			
Type	Turbo Charger Intercooler 4 stroke-cycle, Water-cooled, Direct-injection diesel Engine		
Number of Cylinder	4 in-line		
Piston Displacement (cc)	3.933cc		
		Manual (5 Speed)	Auto (6 Speed)
Max. Power** ps/rpm (kw)	Euro V	170HP/2,500 (125kw) Man	170HP/2,500 (125kw) Man
Max. Torque ** (Nm/rpm)	Euro V	448/1,400 (608nm) Man	448/1,400 (608nm) Man
Fuel System	Injection pump	Denso Common Rail System	

Transmission			
Type	Manual (6 Speed)		Auto (6 Speed)
Version	T060 S6		Allison 1000x fe
Drive	Single Plate Clutch		
Park Pawl	N/A		
PTO	Preperation for PTO		Preperation for PTO
Permissible Torque	147 nm 2000 Rpm		339 nm (min rpm 1200)

Front Axle			
Type	Reverse Elliot type "I" beam		
Capacity	kg	3100 kg	

Rear Axle			
Capacity	kg	6400 kg	

Tyre & Wheel			
Type	Single Front, Dual Rear		
Tyre	Front / Rear	215/75R17.5-12PR	
Wheel	Front / Rear	17.5 x 6.00	

Steering			
Steering	Power Assisted Adjustable Steering Wheel		

Service Brake			
Front / Rear	Disc/Disc		
Vehicle Dynamic Control (VDC)	(ESC) Electronic Stability Control, (ABS) Anti Brake Skid, (HSA) Hill Start Assist, (ESS) Emergency Stop Signal		

Parking Brake			
Actuation	Internal expanding type on Propeller shaft at the rear of Transmission assembly		

Exhaust Brake			
Type	Vacuum operated, Butterfly Valve type		

Suspension			
Type	Front / Rear	Semi-elliptic, laminated Leaf Springs	
Shock absorber	Gas telescopic type on the FRONT/REAR axle		

Exhaust system			
General	Horizontal		

Fuel tank			
Capacity	100ℓ		

Frame			
Type	"H" type frame with channel sectional side rail & cross members, side rail is reinforced with		
Main section side rail dimension (mm)	Depth x Flange x Thickness : 183 x 60 x 6t		

Weights			
*Chassis cab weight kg	Range	2800 -2950 kg	
** Max Gross Vehicle Weight	8,500 kg		
Gross vehicle weight	Front /Rear	3,100 kg/6,400 kg	

Electrical system			
Audio	M450 (Radio+Aux/MP3 USB) Multidisplay		
Auto Locking	Central Door Locking + Power Window + Keyless Entry + Semi Trim		
Steering Wheel Controls	Bluetooth Phone - Audio - Cruise Control		
Head lamps	Semi-sealed Beam / Adjustable Dim		
Front Combination Lamps	Turn signal / Hazard-Amber, Position - White		
Fog Lamps	White		
Rear Combination lamps	Turn signal / Hazard-Amber, Tail / Stop - Red		
License Plate Lamp	White		
Service Lamp Circuit	Yes		
Daytime Running Lights	Yes		
12v Socket in Dash	Yes	x2	
Power Windows	Yes		
Back-up Lamp	White		

Instruments			
Meter Cluster	Fixed type		
Meter	Speedometer / Tachometer / Fuel gauge / Water temperature gauge LCD with odometer / Trip meter / Clock		
Warning Lamps & Indicators	Brake fluid level of reservoir / Parking brake / Oil pressure / Battery charge / Tell-tale lights for head light high beam / Turn signals / Door open / Seat belt / Low fuel		
Horn	Single, Electric		
Cruise Control	Yes		
Heating/ Air conditioning (Manual)	Yes		
Steering Wheel Audio Remote Control	Yes		
Steering Wheel Auto Cruise Control	Yes		

Body / Cab			
Type Mounting	Tilt type with torsion bars, all steel welded construction with safety zone design Rigid or Semi floating type		
Windshield	One piece type with laminated glass, tinted upper section		
Windshield Wipers	Dual electric three speed (intermittent / low / fast) wipers & washer		
Mirrors	Mirror - Heated		
Driver's Seat	Coil Suspension, urethane foam cushioned STD trim		
Passenger's seat	Bench seat, STD Trim		
Steering Column	Fully Adjustable		
Roof Marker Lights	Yes		
Overhead Storage	Yes		
Mirror Width	Narrow STD (optional LONG)		

Active Safety Features			
Electronic Stability Control	Yes		
ABS Braking	Yes		
Daytime Running Lights	Yes		
Hill Start Assist	Yes		
Auto Headlights	Yes		
Bluetooth Hands Free	Yes		
Heated Mirrors	Yes		

Warranty			
Cab Chassis	3 years or 150,000km (whichever occurs first) against manufactures defects		
Upper body	According to supplier		
Refrigeration	Where applicable Any refrigeration supplied will be either from Transcold or Thermo king , all warranty and service s be according to their terms and conditions		

Annotations

- 1) Empty vehicle weight and curb weight shown are to 3.5% variation to allow for production tolerance.
- 2) Empty vehicle weight and curb weight include weight of oil, fuel, coolant and spare tire carrier & bracket, but exclude standard tool set
- 3) The vehicle specification may differ per country.
- 4) Hyundai New Zealand reserves the right to alter the specifications, equipment or options or discontinue the models at any time without prior notice.

*Approximate, depending on variant and specification

**Max GVW includes the front and rear axle loads based on permissible tyre load 5,995kg & 6,500kg variants

images may contain additional cost options

MIGHTY EX9

Cab Chassis

EX9 Std Cab Long Wheelbase

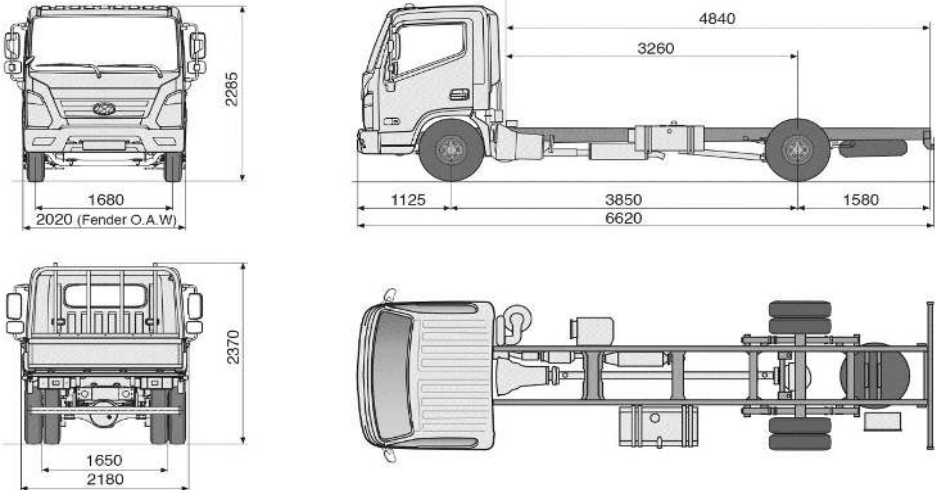

EX9 Std Cab Extra Long Wheelbase

